

PIC-HP: PRICE INTELLIGENT CONTROLLER FOR HYDRONIC PRODUCTS

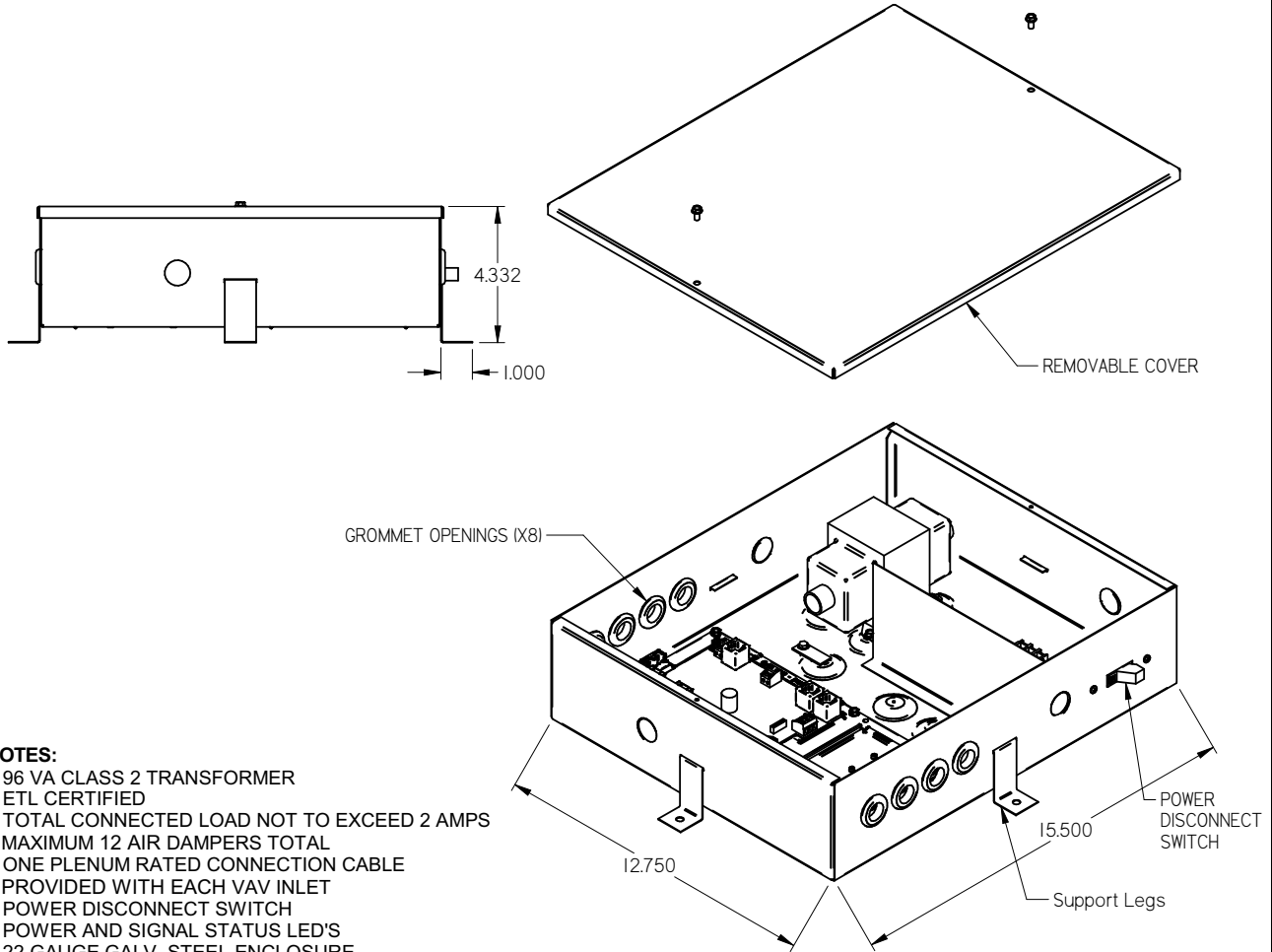

NOTES:

- 96 VA CLASS 2 TRANSFORMER
- ETL CERTIFIED
- TOTAL CONNECTED LOAD NOT TO EXCEED 2 AMPS
- MAXIMUM 12 AIR DAMPERS TOTAL
- ONE PLENUM RATED CONNECTION CABLE PROVIDED WITH EACH VAV INLET
- POWER DISCONNECT SWITCH
- POWER AND SIGNAL STATUS LED'S
- 22 GAUGE GALV. STEEL ENCLOSURE

APPLICATION:

- INPUT SIGNAL FROM DDC CONTROLLER (NO THERMOSTAT) (0 -10V DC COOLING)
- PIC-TS-SENS PRICE ROOM SENSOR THERMOSTAT (SEE SUBMITTAL 250050-100)
- PIC-TS-PRICE DIAL THERMOSTAT (SEE SUBMITTAL 250051-100)
- PIC-TS-LCD PRICE LCD THERMOSTAT (CELCIUS OR FAHRENHEIT OPTION) (SEE SUBMITTAL 250052-100)
- PIC-TS-MOTION PRICE MOTION SENSOR WITH LCD THERMOSTAT (CELCIUS OR FAHRENHEIT OPTION) (SEE SUBMITTAL 250053-100)
- WIRELESS D OPTION - WIRELESS THERMOSTAT (DIAL) AND BASE.

TRANSFORMER OPTIONS:

- 115/24 VAC 96 VA TRANSFORMER
- 277/24 VAC 96 VA TRANSFORMER

ALL METRIC DIMENSIONS () ARE SOFT CONVERTED. IMPERIAL DIMENSIONS ARE CONVERTED TO METRIC AND ROUNDED TO THE NEAREST MILLIMETER.

PROJECT:		PRICE
ENGINEER:		
CUSTOMER:		PIC-HP
SUBMITTAL DATE:		HYDRONIC PRODUCTS CONTROLLER
SPEC. SYMBOL:		DS
		256033
		2010/12/22

FACTORY MOUNTED PIC-HP OPTION

ENCLOSURE IS INSTALLED ON BEAM CASING. WHEN ORDERING TAG THE PIC-HP LINE WITH THE SAME TAG FOR THE REQUIRED BEAM TO ENSURE THEY MATCH UP CORRECTLY

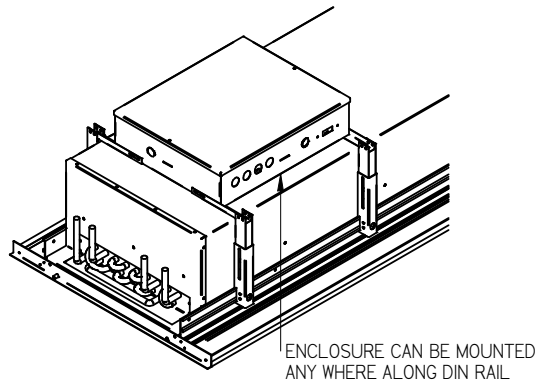
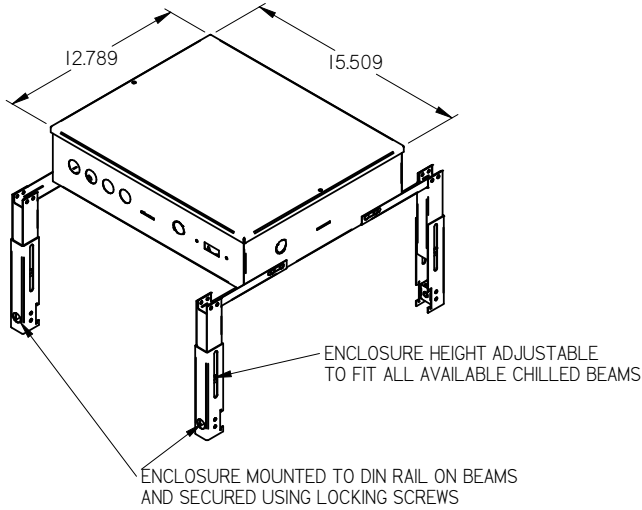

CONDENSATE SENSOR (SHIPPED LOOSE)

•SENSOR CAN BE MOUNTED TO COIL CONNECTIONS OF COIL OR UPSTREAM OF THE BEAM ON THE TUBING

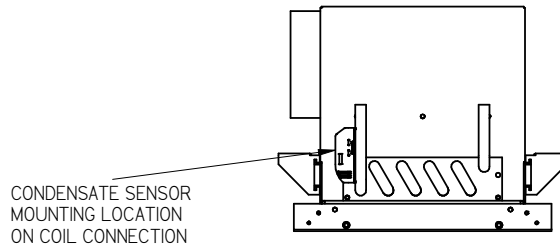
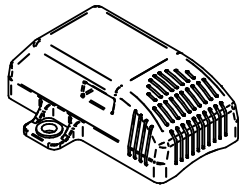

ALL METRIC DIMENSIONS () ARE SOFT CONVERTED. IMPERIAL DIMENSIONS ARE CONVERTED TO METRIC AND ROUNDED TO THE NEAREST MILLIMETER.

PROJECT:		PRICE	
ENGINEER:		DS	PIC-HP HYDRONIC PRODUCTS CONTROLLER
CUSTOMER:		256033	
SUBMITTAL DATE:	SPEC. SYMBOL:	2010/12/22	